

# Flat-screen television stand

## Instruction manual

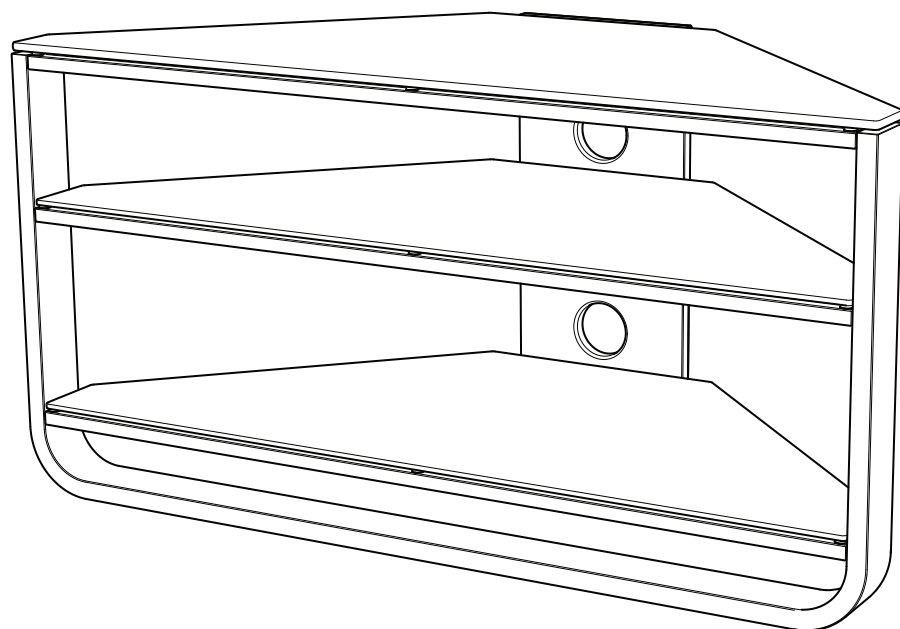

John Lewis

Thank you for purchasing this flat-screen television stand. Please read the instructions carefully to ensure safe and satisfactory operation of this product. Retain this information for future reference.

## WARNING!

- Before starting this assembly please take time to familiarise yourself with the components listed on the back page.
- Do not place very hot or very cold items against or in close proximity to glass surfaces unless an adequately thick insulating material is used to prevent such items coming into contact with the glass.
- Do not strike the glass with hard or pointed items.
- When cleaning glass panels use a damp cloth or leather with washing up liquid or soft soap if necessary; do not use washing powders or any other substance containing abrasives as these substances scratch glass.
- Do not sit or stand upon horizontal glass surfaces.
- **Maximum safe load for top glass shelf is 100kg.**

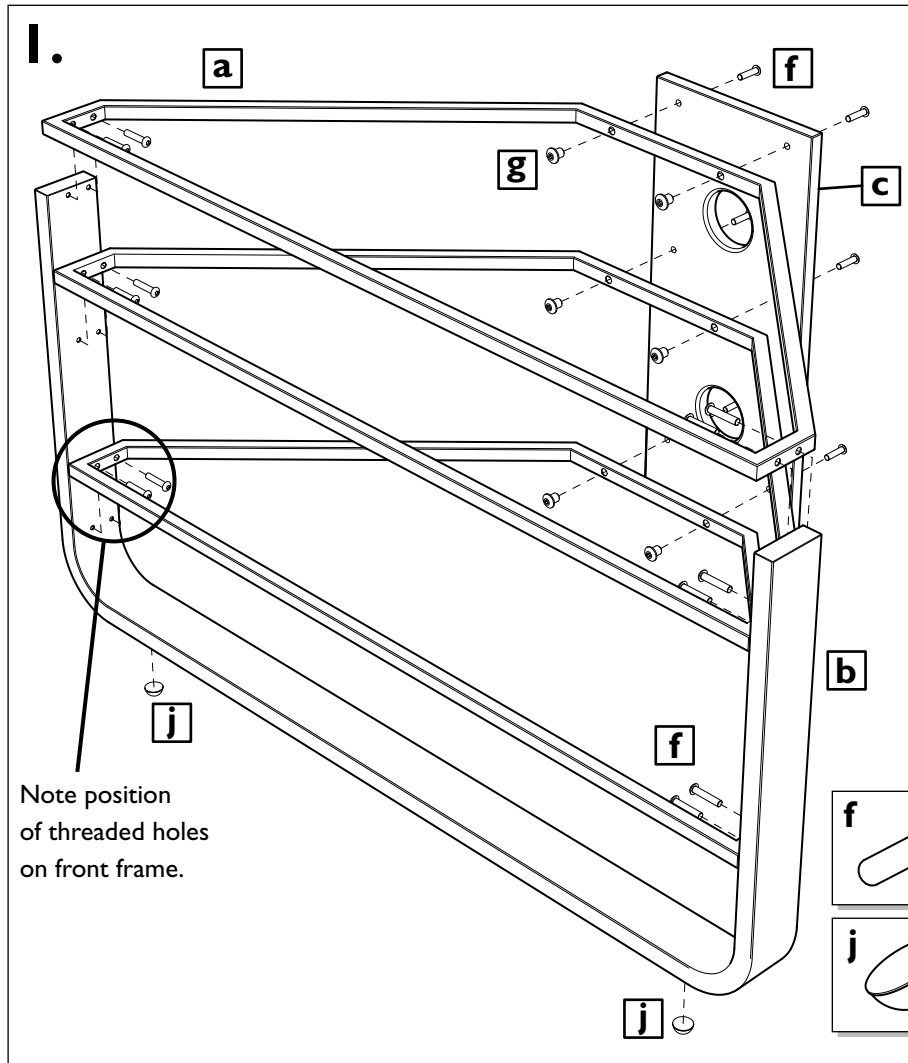

## Stage I

- Assemble shelf frames **a** onto front frame **b** using fixing screws **f**. Only tighten screws "finger-tight" at this stage.
- Attach back panel **c** to shelf frames using sleeve nuts **g** and fixing screws **f**. Again, only tighten screws "finger-tight" at this stage.
- Remove protective backing off self-adhesive plastic feet **j** and attach to underside of front frame.

## Stage 2

- Attach 6 self-adhesive clear plastic buffers **k** to each shelf frame. Position one buffer in each corner and one centrally at the front and rear of the frame as shown on the right.
- Carefully place top glass shelf **d** (8mm glass) onto the 6 clear plastic buffers on the top shelf frame. The black printed side of the glass should be on the underside.
- Carefully insert the two remaining glass shelves **e** (5mm glass) onto plastic buffers on the remaining shelf frames. Take extra care not to damage either the legs or back panel during this stage.
- Fully tighten all screws to secure assembly.

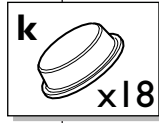

2.

**k**

**d**

**e**

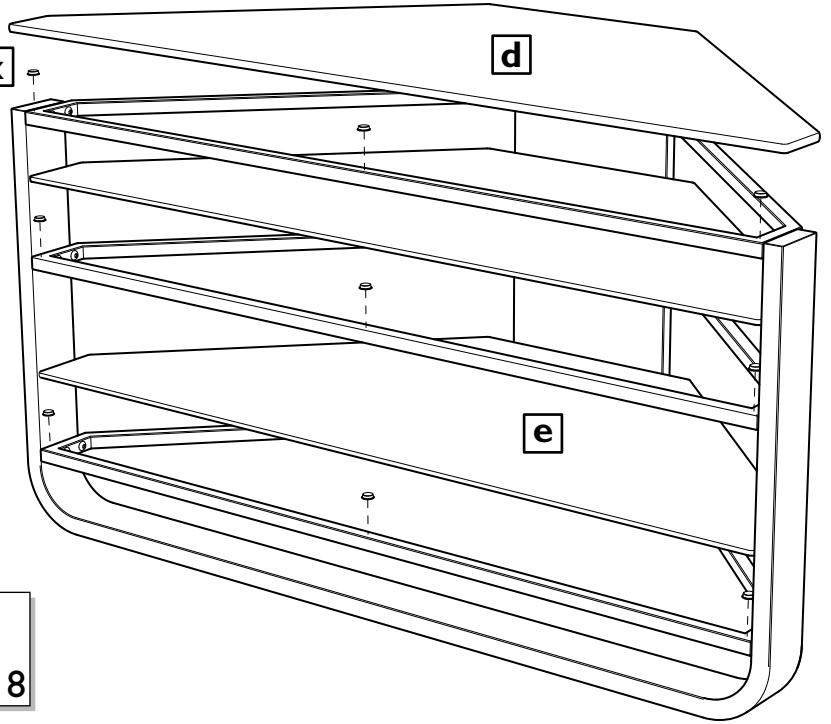

3.

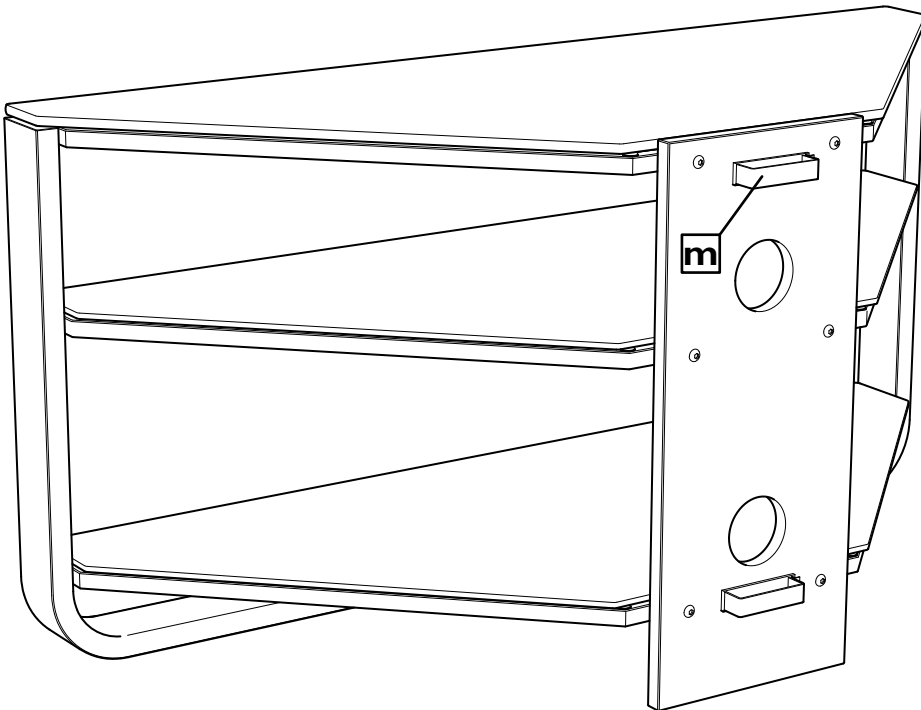







## Stage 3

- Peel protective backing from self-adhesive strips on cable tidy clips **m**.
- Firmly attach cable tidy mouldings to rear of back panel.
- The mouldings can be simply 'un-clipped' to allow cable access and then 'clipped' back into place to keep the cables captive.

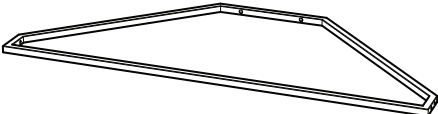
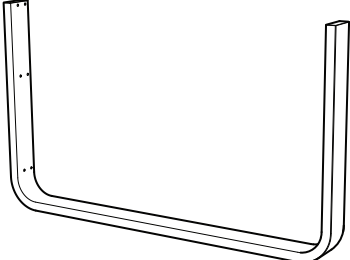
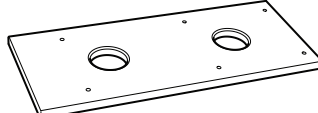
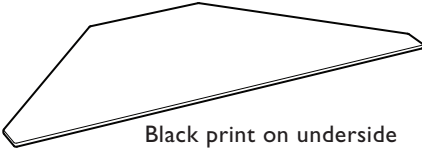
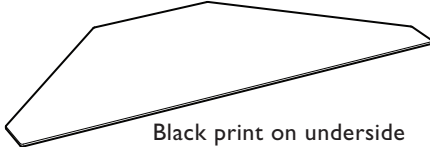
# Flat-screen television stand

John Lewis JL3/95-CB

## Certificate of conformity

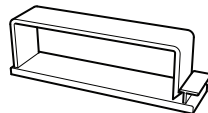
Component		Description	Qty	Packed by
	<b>a</b>	Shelf frame	3	
	<b>b</b>	Front frame	1	
	<b>c</b>	Back panel	1	
 Black print on underside	<b>d</b>	Glass top shelf (8mm thick)	1	
 Black print on underside	<b>e</b>	Glass shelf (5mm thick)	2	
	<b>f</b>	Fixing screw	18	
	<b>g</b>	Sleeve nut	6	
	<b>h</b>	Allen key	2	
	<b>j</b>	Self-adhesive soft plastic feet	2	
	<b>k</b>	Self-adhesive clear plastic buffers	18	
	<b>m</b>	Cable tidy clips	2	